

PRODUCT DATA SHEET

Part number 310SL

EAN 4015609380251

Manufacturer WALTHER-WERKE

WEEE-Reg.-Number: DE 22131895

Product description

Coupler 16A 5P 6h screwless and with external cable gland



Similar image



Detailed product description

WALTHER Coupler 16A 5P 400V 6h IP44
 made from PA6 material
 screwless
 with insulation displacement technique
 and external cable gland
 Increased safety due to injected 2K seal.

Ordering Information

| | |
|-------------------------|----------|
| Order unit | Piece |
| Customs number | 85366990 |
| Net weight | 0,291 kg |
| Packing quantity (VPE) | 10 |
| Length of the packaging | 0,31 m |
| Width of the packaging | 0,195 m |
| Depth of the packaging | 0,14 m |
| Gross weight(VPE) | 3,058 kg |

Certificates

| | | |
|------------------------|-----------------------|---|
| VDE/ENEC certification | 40024796 |  |
| EAC certification | BY112.02.01.020 06101 |  |

Classification system

| | |
|-----------------------|----------|
| Classification system | ETIM_6.0 |
| ETIM Class | EC001320 |

Technical product data

| | |
|---------------------------------------|----------------------|
| IEC-amperage | 16 A |
| Amperage acc. UL/CSA (for UL-version) | 20 A |
| Number of poles | 5 |
| Voltage acc. EN 60309-2 | 400 V (50+60 Hz) red |
| Clock hour position | 6 h |
| Identification colour | Red |
| RAL-number | 3000 |
| Degree of protection (IP) | IP44 |
| Connection system | Screw less terminal |
| Angle of plug | Straight |
| Cable entry | Swivel |
| Material | Plastic |

Dimension sheet

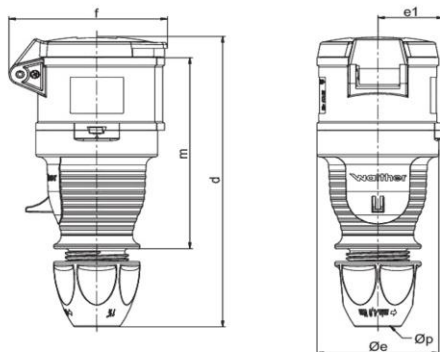

| Amp. | 16 | 16 | 32 | 32 | 32 |
|------|------------|------------|-----------|-----------|-----------|
| Pole | 4 | 5 | 3 | 4 | 5 |
| d | 165-176 | 165-176 | 189-199 | 189-199 | 189-199 |
| Øe | 65 | 65 | 72 | 72 | 72 |
| e1 | 35 | 35 | 38,5 | 38,5 | 38,5 |
| f | 77 | 85 | 91 | 91 | 97 |
| m | 114 | 114 | 130 | 130 | 130 |
| Øp | 7,5 - 18,5 | 7,5 - 18,5 | 10 - 22,5 | 10 - 22,5 | 10 - 22,5 |