

With or without terminals

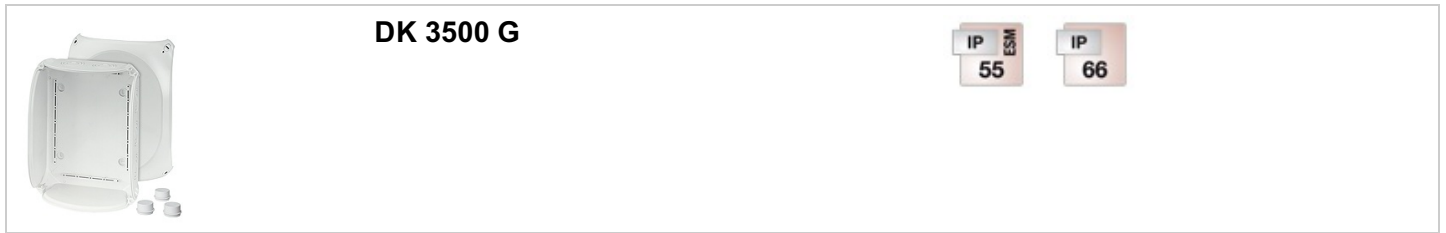

DK 3500 G

IP 55 ESM

IP 66

- without terminals
- included cable entry: 3 ESM 40, sealing range Ø 17-30 mm
- with two cable entries M 32 from the rear side
- lid fasteners sealable without accessories
- External brackets for wall fixing included
- Colour: grey, RAL 7035

material	PC (polycarbonate)
degree of protection:	IP 55 (ESM)
degree of protection:	IP 66 (AKM)
mounting width	260 mm
mounting height	190 mm
max. installation depth	106 mm
width	295 mm
height	225 mm
depth	122 mm
weight	1,053 kg
in accordance with	IEC 60670-22

Drawings

Dimension drawing

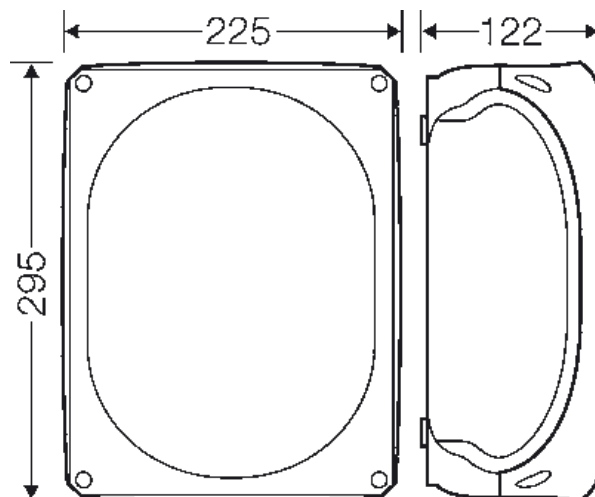

With or without terminals

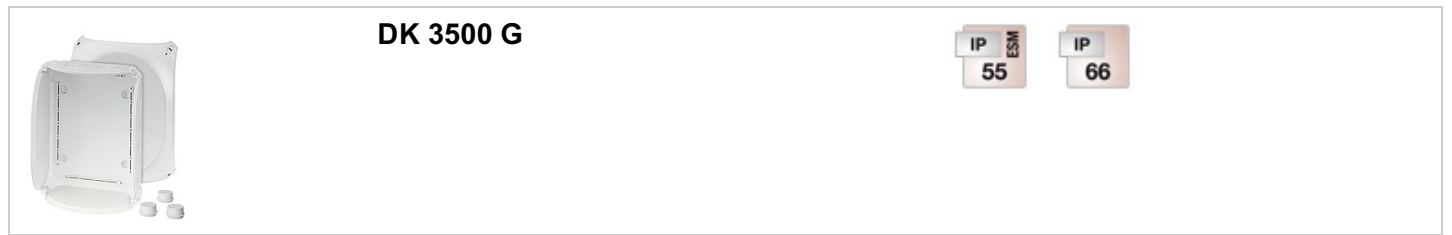

DK 3500 G



Detail mass

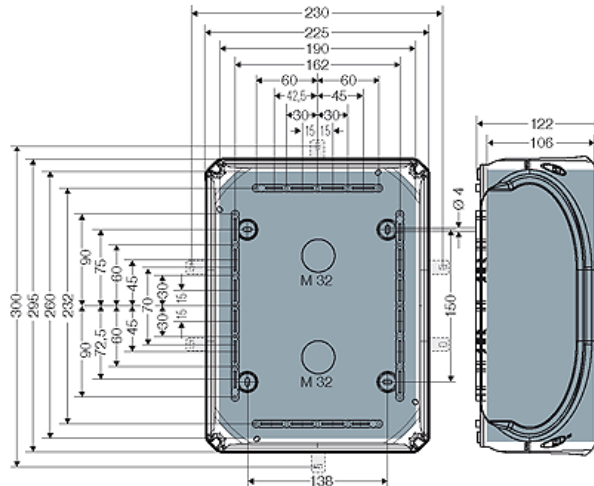

Box walls

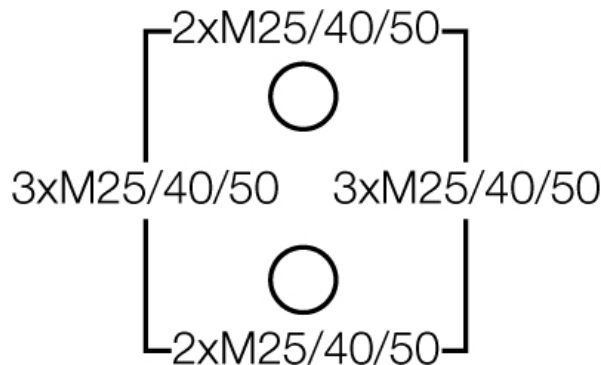

Operating and ambient conditions

Application area	Suitable for indoor installation and outdoor installation, protected against weather influences
Ambient temperature	Maximum value + 40 °C Minimum value - 25 °C
Fire protection in the event of internal faults	Demands placed on electrical devices from standards and laws Minimum requirements - Glow wire test in accordance with IEC 60695-2-11: - 650°C for boxes and cable glands - 850°C for parts of insulating material necessary to retain current carrying parts in position
Burning behaviour	Glow wire test IEC 60695-2-11: 750 °C UL Subject 94: V-2 flame-retardant self-extinguishing
Degree of protection against mechanical load	IK07 (2 Joule)
Toxic behaviour	halogen-free silicone-free "halogen-free" in accordance with the examination of the cables and insulated wires - corrosiveness of fumes - as per IEC 60 754-2
Note:	For material properties see technical data.