

Extension frame



FP ZR 30

- Extension frame
- for enclosures size 3

- for extension of the installation depth by 50 mm
- inclusive fixing material
- suitable for the admission of cover FP AP 30 in different installation depths

weight	1,003 kg
depth	50 mm
height	540 mm
width	270 mm

Drawings

Dimension drawing

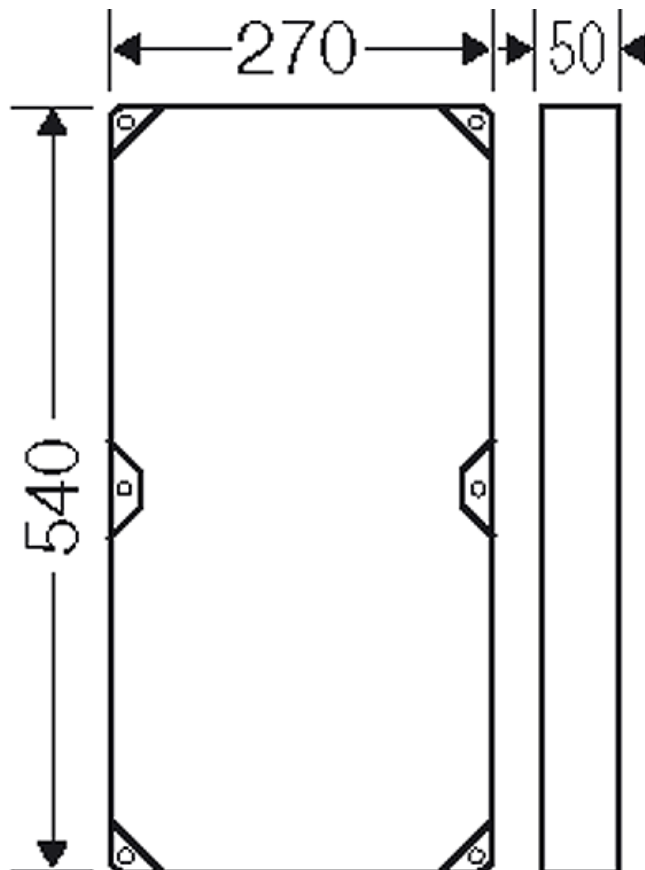

Operating and ambient conditions

Application area	Suitable for indoor installation and outdoor installation, protected against weather influences However, pay attention to the climatic effects on the installed equipment , for example, high or low ambient temperatures or formation of condensed water see technical information
Ambient temperature	Maximum value + 70 °C Minimum value - 25 °C
Fire protection in the event of internal faults	Demands placed on electrical devices from standards and laws Minimum requirements - Glow wire test in accordance with IEC 60695-2-11: - 650°C for boxes and cable glands - 850°C for parts of insulating material necessary to retain current carrying parts in position
Burning behaviour	Glow wire test IEC 60695-2-11: 960 °C UL Subject 94: V-2 flame-retardant self-extinguishing
Degree of protection against mechanical load	IK08 (5 Joule)
Toxic behaviour	halogen-free silicone-free "halogen-free" in accordance with the examination of the cables and insulated wires - corrosiveness of fumes - as per IEC 60754-2
Note:	Additional information for protected outdoor installation: - In order to keep the maximum permissible ambient temperature of the installed equipment as well for the prevention from condensation additional measures as ventilation and/or heating may be necessary. For material properties see technical data.