



Monitoring relays - GAMMA series

Multifunction

Fault latch

Supply voltage selectable via power modules

2 change-over contacts

Width 22.5mm

Industrial design



Technical data

1. Functions

3-phase current monitoring with adjustable thresholds, timing for start-up suppression and tripping delay separately adjustable and the following functions which are selectable by means of rotary switch:

OVER	Overcurrent monitoring
OVER+LATCH	Overcurrent monitoring with fault latch
UNDER	Undercurrent monitoring
UNDER+LATCH	Undercurrent monitoring with fault latch
WIN	Monitoring the window between Min and Max
WIN+LATCH	Monitoring the window between Min and Max with fault latch

2. Time ranges

	Adjustment range
Start-up suppression time:	0s 10s
Tripping delay:	0.1s 10s

3. Indicators

Green LED ON:	indication of supply voltage
Red LED ON/OFF:	indication of failure of the corresponding threshold
Red LED flashing:	indication of tripping delay of the corresponding threshold
Yellow LED ON/OFF:	indication of relay output

4. Mechanical design

Self-extinguishing plastic housing, IP rating IP40
 Mounted on DIN-Rail TS 35 according to EN 60715
 Mounting position: any. Shockproof terminal connection according to VBG 4 (PZ1 required), IP rating IP20
 Tightening torque: max. 1Nm
 Terminal capacity:
 1 x 0.5 to 2.5mm² with/without multicore cable end
 1 x 4mm² without multicore cable end
 2 x 0.5 to 1.5mm² with/without multicore cable end
 2 x 2.5mm² flexible without multicore cable end

5. Input circuit

Supply voltage:	12 to 400V AC	terminals A1-A2 (galvanically separated) selectable via power modules TR2
Tolerance:		according to specification of power module
Rated frequency:		according to specification of power module
Rated consumption:	2VA (1.5W)	
Duration of operation:	100%	
Reset time:	100ms	
Residual ripple for DC:	-	
Drop-out voltage:	>30% of the supply voltage	
Overvoltage category:	III (in accordance with IEC 60664-1)	
Rated surge voltage:	4kV	

6. Output circuit

2 potential free change-over contacts	
Rated voltage:	250V AC
Switching capacity:	750VA (3A / 250V AC)
If the distance between the devices is less than 5mm!	
Switching capacity:	1250VA (5A / 250V AC)
Fusing:	5A fast acting
If the distance between the devices is greater than 5mm!	
Mechanical life:	20 x 10 ⁶ operations
Electrical life:	2 x 10 ⁵ operations at 1000VA resistive load
Switching frequency:	max. 60/min at 100VA resistive load max. 6/min at 1000VA resistive load (in accordance with IEC 60947-5-1)
Overvoltage category:	III (in accordance with IEC 60664-1)
Rated surge voltage:	4kV

7. Measuring circuit

Measured variable:	AC Sinus (48 to 63Hz)
Input:	5A AC, terminals K-11, K-12, K-13 (distance >5mm)
Overload capacity:	6A AC
Input resistance:	10mΩ
Switching threshold	
Max:	10% to 100% of I _N
Min:	5% to 95% of I _N
Overvoltage category:	III (in accordance with IEC 60664-1)
Rated surge voltage:	4kV

8. Accuracy

Base accuracy:	≤3% (of maximum scale value)
Frequency response:	-10% to +5% (at 16.6 to 400Hz)
Adjustment accuracy:	≤5% (of maximum scale value)
Repetition accuracy:	≤2%
Voltage influence:	-
Temperature influence:	≤0.05% / °C

9. Ambient conditions

Ambient temperature:	-25 to +55°C (in accordance with IEC 60068-1) -25 to +40°C (in accordance with UL 508)
Storage temperature:	-25 to +70°C
Transport temperature:	-25 to +70°C
Relative humidity:	15% to 85% (in accordance with IEC 60721-3-3 class 3K3)
Pollution degree:	3 (in accordance with IEC 60664-1)
Vibration resistance:	10 to 55Hz 0.35mm (in accordance with IEC 60068-2-6)
Shock resistance:	15g 11ms (in accordance with IEC 60068-2-27)

Functions

For all the functions the LEDs MIN and MAX are flashing alternating, when the minimum value for the measured current was chosen to be greater than the maximum value.

If a failure already exists when the device is activated, the output relays remain in off-position and the LED for the corresponding threshold is illuminated.

Overcurrent monitoring (OVER, OVER+LATCH)

When the measured current of one of the phases exceeds the value adjusted at the MAX-regulator, the set interval of the tripping delay (DELAY) begins (red LED MAX flashes). After the interval has expired (red LED MAX illuminated), the output relays switch into off-position (yellow LED not illuminated). The output relays again switch into on-position (yellow LED illuminated), when the measured current of all the phases falls below the value adjusted at the MIN-regulator (red LED MAX not illuminated). If the fault latch is activated (OVER+LATCH) and the measured current of one of the phases remains above the MAX-value longer than the set interval of the tripping delay, the output relays remain in the off-position even if the measured current of all the phases falls below the value adjusted at the MIN-regulator. After resetting the failure (interrupting and re-applying the supply voltage), the output relays switch into on-position and a new measuring cycle begins with the set interval of the start-up suppression (START).

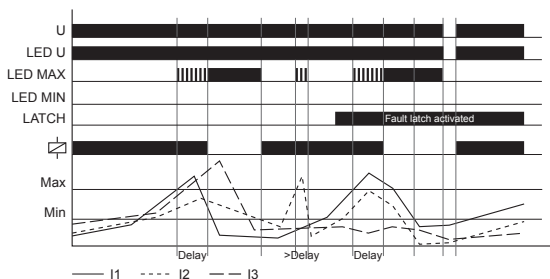

Undercurrent monitoring (UNDER, UNDER+LATCH)

When the measured current of one of the phases falls below the value adjusted at the MIN-regulator, the set interval of the tripping delay (DELAY) begins (red LED MIN flashes). After the interval has expired (red LED MIN illuminated), the output relays switch into off-position (yellow LED not illuminated). The output relays again switch into on-position (yellow LED illuminated), when the measured current of all the phases exceeds the value adjusted at the MAX-regulator. If the fault latch is activated (UNDER+LATCH) and the measured current of one of the phases remains below the MIN-value longer than the set interval of the tripping delay, the output relays remain in the off-position even if the measured current of all the phases exceeds the value adjusted at the MAX-regulator. After resetting the failure (interrupting and re-applying the supply voltage), the output relays switch into on-position and a new measuring cycle begins with the set interval of the start-up suppression (START).

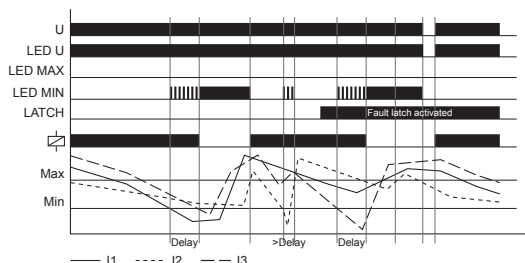

Window function (WIN, WIN+LATCH)

The output relays switch into on-position (yellow LED illuminated) when the measured current of all the phases exceeds the value adjusted at the MIN-regulator. When the measured current of one of the phases exceeds the value adjusted at the MAX-regulator, the set interval of the tripping delay (DELAY) begins (red LED MAX flashes). After the interval has expired (red LED MAX illuminated), the output relays switch into off-position (yellow LED not illuminated). The output relays again switch into on-position (yellow LED illuminated) when the measured current of all the phases falls below the value adjusted at the MAX-regulator (red LED MAX not illuminated). When the measured current of one of the phases falls below the value adjusted at the MIN-regulator, the set interval of the tripping delay (DELAY) begins again (red LED MIN flashes). After the interval has expired (red LED MIN illuminated), the output relays switch into off-position (yellow LED not illuminated).

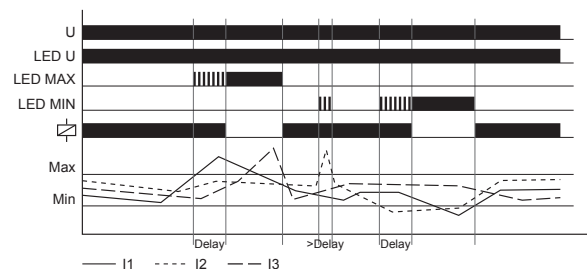

If the fault latch is activated (WIN+LATCH) and the measured current of one of the phases remains below the MIN-value longer than the set interval of the tripping delay, the output relays remain in the off-position even if the measured current of all the phases exceeds the value adjusted at the MIN-regulator. If the measured current of one of the phases remains above the MAX-value longer than the set interval of the tripping delay, the output relays remain in the off-position even if the measured current of all the phases falls below the value adjusted at the MAX-regulator. After resetting the failure (interrupting and re-applying the supply voltage), the output relays switch into on-position and a new measuring cycle begins with the set interval of the start-up suppression (START).

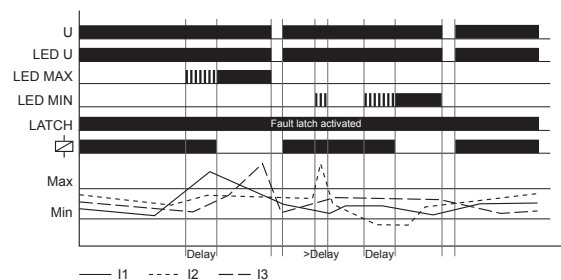

Connections

G2JM5AL20 with power modul 24V AC without fault latch

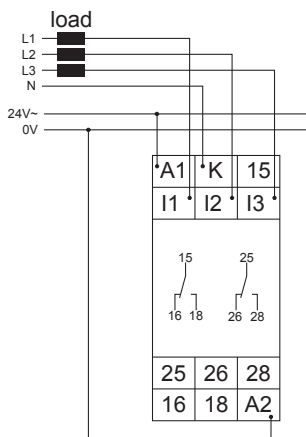

G2JM5AL20 with power modul 230V AC and current transformer

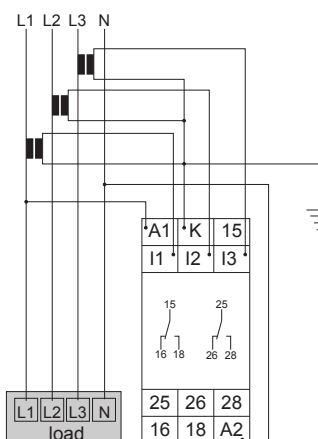

G2JM5AL20 with power modul 230V AC with fault latch

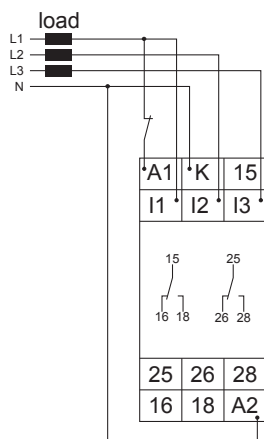

Dimensions

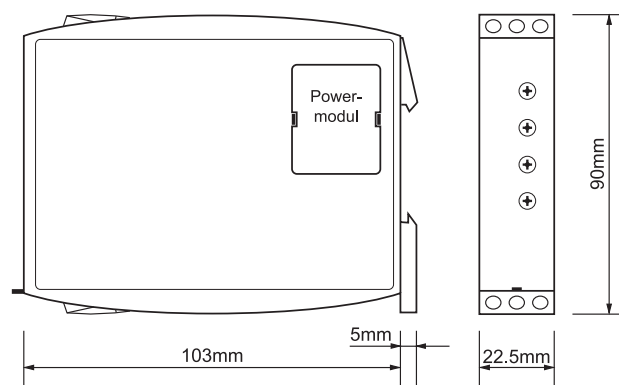

G2JM5AL20 with power modul 400V AC without fault latch

