

# Wire end sleeve uninsulated 16 mm<sup>2</sup> - 12 mm B16012

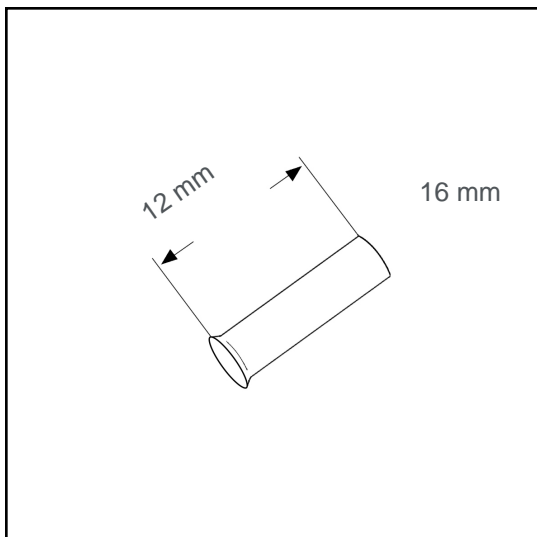

## Datasheet:

Cross section (mm <sup>2</sup> ):	16
AWG:	6
Length (mm):	12
Material:	E-Cu
Surface:	tin plated
Minimum thickness of tin coating:	3 µm
Max. Temp:	105°C
REACH/RoHS:	confirmed
Certificates:	UL
DIN:	DIN 46228 T1

## Packing sizes:

250 pcs.:	Part no.: 006079
5 x 100 pcs.:	Part no.: 010579
pcs.:	Part no.: 005438

## Dimensions (mm):

l1	d1	s1	d2
12	5.8	0.2	7.5

