

Wire end sleeve uninsulated 2.5 mm² - 12 mm B02512

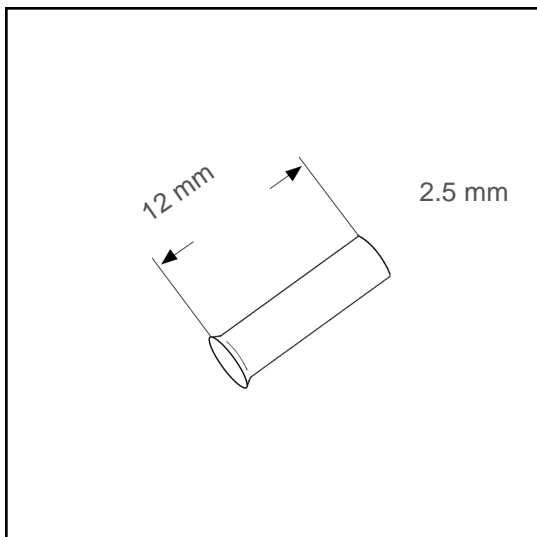

Datasheet:

Cross section (mm ²):	2.5
AWG:	14
Length (mm):	12
Material:	E-Cu
Surface:	tin plated
Minimum thickness of tin coating:	3 µm
Max. Temp:	105°C
REACH/RoHS:	confirmed
Certificates:	UL
DIN:	DIN 46228 T1

Packing sizes:

1000 pcs.:	Part no.: 006045
pcs.:	Part no.: 005412

Dimensions (mm):

l1	d1	s1	d2
12	2.2	0.15	3.4

