

Wire end sleeve insulated twin 1 mm² - 12 mm A01087TWIN

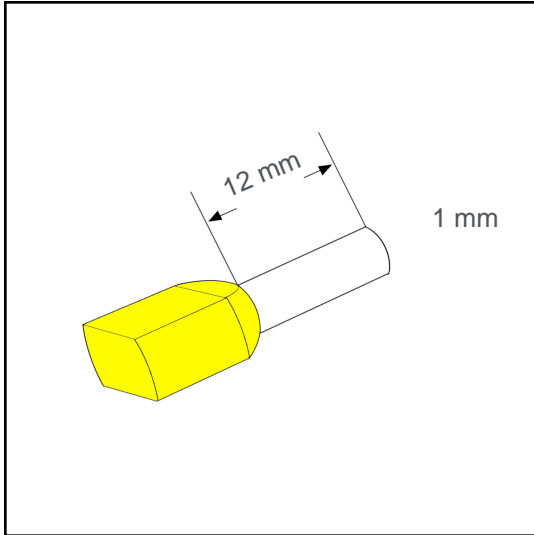

Datasheet:

Cross section (mm ²):	1
AWG:	2x18
Length (mm):	12
Color:	yellow
Material:	E-Cu / Polypropylene
Surface:	tin plated
Minimum thickness of tin coating:	3 μm
Max. Temp:	105°C
REACH/RoHS:	confirmed

for two wires in one ferrule

Packing sizes:

500 pcs.:	Part no.: 005755
10 x 100 pcs.:	Part no.: 005754
50000 pcs.:	Part no.: 005260

Dimensions (mm):

l1	l2	d1	s1	d2	s2	d3
19	12	2.05	0.15	3.3	0.3	5.3

