

# Wire end sleeve insulated twin 2.5 mm<sup>2</sup> - 10 mm A02555TWIN

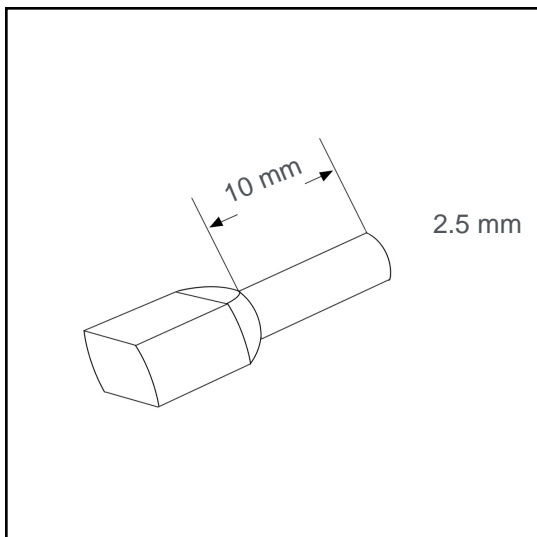

## Datasheet:

Cross section (mm <sup>2</sup> ):	2.5
AWG:	2x14
Length (mm):	10
Color:	blue
Material:	E-Cu / Polypropylene
Surface:	tin plated
Minimum thickness of tin coating:	3 μm
Max. Temp:	105°C
REACH/RoHS:	confirmed
Certificates:	UL

for two wires in one ferrule

## Packing sizes:

250 pcs.: Part no.: 005826

25000 pcs.: Part no.: 005267

## Dimensions (mm):

l1	l2	d1	s1	d2	s2	d3
18.5	10	2.9	0.2	4	0.4	7.6

