



Monitoring relays - KAPPA series

Multifunction

2 change over contacts

Plug-in housing

Width 38mm



Read and understand these instructions before installing, operating or maintaining the equipment.



Danger!

Never carry out work on live parts! Danger of fatal injury! The product must not be used in case of obvious damage. To be installed by an authorized person.

Technical data

1. Functions

a.c. current monitoring in 1-phase mains with adjustable thresholds, timing for start-up suppression and tripping delay separately adjustable and the following functions, which are selected by means of rotary switch:

OVER	Overcurrent monitoring
UNDER	Undercurrent monitoring
WIN	Monitoring the window between Min and Max
OVER+Latch	Overcurrent monitoring with fault latch
UNDER+Latch	Undercurrent monitoring with fault latch
WIN+Latch	Monitoring the window between Min and Max with fault latch

2. Time ranges

	Adjustment range
Start-up suppression time (Start):	0 10s
Tripping delay (Delay):	0.1 10s

3. Indicators

Green LED U/t ON/OFF:	indication of supply voltage
Green LED U/t flashes:	indication of start-up suppression time
Red LED Min/Max ON/OFF:	indication of failure of the corresponding threshold
Red LED Min/Max flashes:	indication of tripping delay of the corresponding threshold
Yellow LED ON/OFF:	indication of relay output

4. Mechanical design

Self-extinguishing plastic housing, IP rating IP40
 Mounted on screw terminal socket 11-pols in accordance with IEC 60067-1-18a (type R11X or PF113BE/M)
 Mounting position: any
 Sockproof terminal connection according to VBG 4 (PZ1 required),

5. Input circuit

Supply voltage:	230V a.c.
Pins:	S2-S10 / A1-A2
Tolerance:	-15% to +10% of U_N
Rated consumption:	8VA (1W)
Rated frequency:	a.c. 48 to 63Hz
Duration of operation:	100%
Reset time:	500ms
Wave form:	Sinus
Hold-up time:	-
Drop-out voltage:	>20% of supply voltage
Overvoltage category:	III (in accordance with IEC 60664-1)
Rated surge voltage:	4kV

6. Output circuit

2 potential free change over contacts	
Rated voltage:	250V a.c.
Switching capacity:	1250VA (5A / 250V)
Fusing:	5A fast acting
Mechanical life:	20 x 10 ⁶ operations
Electrical life:	2 x 10 ⁵ operations
Switching frequency:	max. 6/min at 1000VA resistive load (in accordance with IEC 60947-5-1)
Overvoltage category:	III (in accordance with IEC 60664-1)
Rated surge voltage:	4kV

7. Measuring circuit

Measuring variable:	a.c. Sinus, 48 to 63Hz
Measuring input:	5A a.c. (galvanically separated)
Pins:	S5-S7 / i-k
Overload capacity:	10A
Starting current:	100A
	50A
Input resistance:	<10mΩ
Switching threshold I_G :	see table ordering information or printing on the unit
Overvoltage category:	III (in accordance with IEC 60664-1)
Rated surge voltage:	4kV

8. Accuracy

Base accuracy:	±5% of nominal value
Adjustment accuracy:	±5% of nominal value
Repetition accuracy:	±2% of nominal value
Voltage influence:	-
Temperature influence:	0.05% / °C

9. Ambient conditions

Ambient temperature:	-25 to +55°C
Storage temperature:	-25 to +70°C
Transport temperature:	-25 to +70°C
Relative humidity:	15% to 85% (in accordance with IEC 60721-3-3 class 3K3)
Pollution degree:	2 (in accordance with IEC 60664-1)

Functions

Overcurrent monitoring (OVER, OVER+Latch)

When the supply voltage U is applied, the output relay R switches into on-position and the set interval of the start-up suppression (Start) begins. Changes of the measured current during this period do not affect the state of the output relay R.

When the measured current exceeds the Max-value, the output relay R switches into off-position after the interval of the tripping delay (Delay) has expired.

OVER:

The output relay R switches into on-position again, if the current falls below the Min-value.

OVER+Latch:

The output relay R switches only into on-position again by interrupting and re-applying of the supply voltage and a new measuring cycle begins with the set interval of the start-up suppression time (Start).

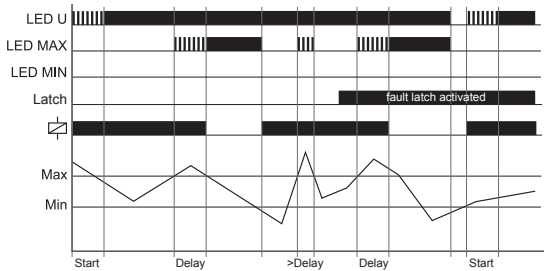

Window function (WIN, WIN+Latch)

When the supply voltage U is applied, the output relay R switches into on-position and the set interval of the start-up suppression (Start) begins. Changes of the measured current during this period do not affect the state of the output relay R.

When the measured current leaves the window between Min and Max, the output relay R switches into off-position after the interval of the tripping delay (Delay) has expired.

WIN:

The output relay R switches into on-position again, if the current re-enter the adjusted window.

WIN+Latch:

The output relay R switches only into on-position again by interrupting and re-applying of the supply voltage and a new measuring cycle begins with the set interval of the start-up suppression time (Start).

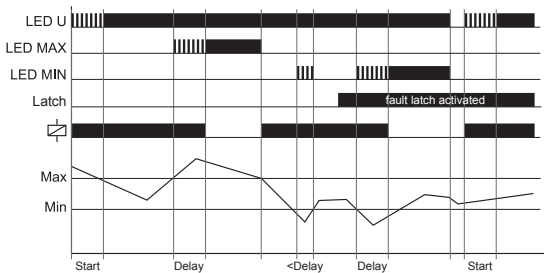

Under current monitoring (UNDER, UNDER+Latch)

When the supply voltage U is applied, the output relay R switches into on-position and the set interval of the start-up suppression (Start) begins. Changes of the measured current during this period do not affect the state of the output relay R.

When the measured current falls below the Min-value, the output relay R switches into off-position after the interval of the tripping delay (Delay) has expired.

UNDER:

The output relay R switches into on-position again, if the current exceeds the Max-value.

UNDER+Latch:

The output relay R switches only into on-position again by interrupting and re-applying of the supply voltage and a new measuring cycle begins with the set interval of the start-up suppression time (Start).

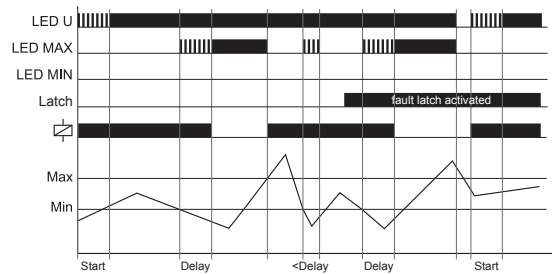

Connections

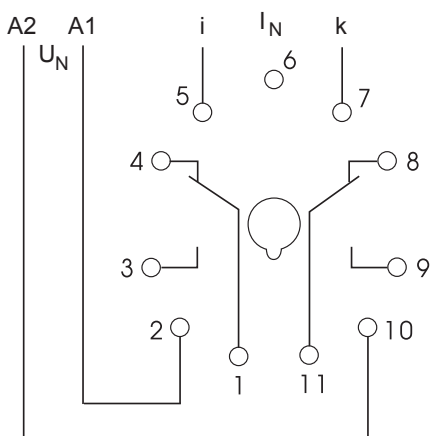

Dimensions

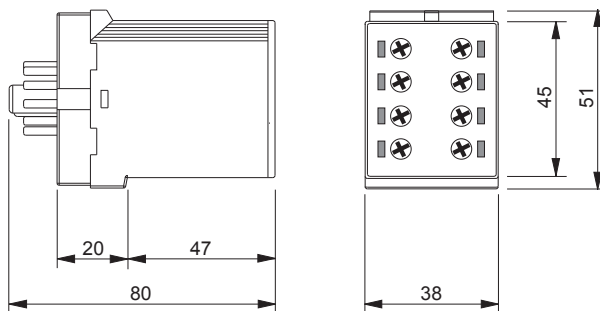

Ordering information

Type	Rated voltage U_N	Functions	Switching thresholds I_s	Start-up suppression time (Start)	Tripping delay (Delay)	Part. No.
K3IM5AACL20	230V a.c.	O, U, W, O+L, U+L, W+L	Max: 10% to 100% of I_N Min: 5% to 95% of I_N	0s to 10s	0,1s bis 10s	1380202