

LMK 382



Stainless Steel Probe

Ceramic Sensor

accuracy according to IEC 60770:
standard: 0.35 % FSO
option: 0.25 % FSO

Nominal pressure

from 0 ... 40 cmH₂O up to 0 ... 200 mH₂O

Output signals

2-wire: 4 ... 20 mA
3-wire: 0 ... 10 V
others on request

Special characteristics

- ▶ diameter 39.5 mm
- ▶ especially for sewage, viscous and pasty media

Optional versions

- ▶ IS-version
Ex ia = intrinsically safe for gas and dust
- ▶ temperature element Pt 100
- ▶ mounting with stainless steel pipe
- ▶ flange version
- ▶ diaphragm 99.9 % Al₂O₃
- ▶ different kinds of cables and elastomers

The stainless steel probe LMK 382 has been designed for continuous level measurement in waste water, polluted and higher viscosity media.

Basic element is a robust and high overpressure capable capacitive ceramic sensor which is suitable e. g. for low levels.

Preferred areas of use are



Water

drinking water abstraction



Sewage

waste water treatment
water recycling



Fuel and oil

level monitoring in open tanks
with low filling heights
fuel storage
tank farms / biogas plants



LMK 382

Stainless Steel Probe

Technical Data

Input pressure range															
Nominal pressure gauge [bar]	0.04	0.06	0.1	0.16	0.25	0.4	0.6	1	1.6	2.5	4	6	10	16	20
Level [mH ₂ O]	0.4	0.6	1	1.6	2.5	4	6	10	16	25	40	60	100	160	200
Overpressure [bar]	2	2	4	4	6	6	8	8	15	25	25	35	35	45	45
Max. ambient pressure (housing): 40 bar															

Output signal / Supply	
Standard	2-wire: 4 ... 20 mA / V _S = 9 ... 32 V _{DC}
Option IS-version	2-wire: 4 ... 20 mA / V _S = 14 ... 28 V _{DC}
Option 3-wire	3-wire: 0 ... 10 V / V _S = 12.5 ... 32 V _{DC}

Option temperature element Pt 100 ¹	
Temperature range	-25 ... 125 °C
Connectivity technology	3-wire
Resistance	100 Ω at 0 °C
Temperature coefficient	3850 ppm/K
Supply I _S	0.3 ... 1.0 mA _{DC}
max. voltage 10 V _{DC} , in intrinsically safe circuit 30 V _{DC} max. current 2 mA, in intrinsically safe circuit 54 mA max. power 10 mW, in intrinsically safe circuit 405 mW	

¹ only in combination with 4 ... 20 mA / 2-wire (standard and IS-version)

Performance	
Accuracy ²	standard: ≤ ± 0.35 % FSO option: ≤ ± 0.25 % FSO
Permissible load	$R_{max} = [(V_S - V_{Smin}) / 0.02 A] \Omega$
Influence effects	supply: 0.05 % FSO / 10 V load: 0.05 % FSO / kΩ
Long term stability	≤ ± 0.1 % FSO / year at reference conditions
Turn-on time	700 msec
Mean response time	< 200 msec measuring rate 5/sec
Max. response time	380 msec

² accuracy according to IEC 60770 – limit point adjustment (non-linearity, hysteresis, repeatability)

Thermal effects (offset and span)	
Tolerance band	≤ ± 1 % FSO
in compensated range	-20 ... 80 °C

Permissible temperatures	
Permissible temperatures	medium / electronics / environment / storage: -25 ... 125 °C

Electrical protection ³	
Short-circuit protection	permanent
Reverse polarity protection	no damage, but also no function
Electromagnetic compatibility	emission and immunity according to EN 61326

³ additional external overvoltage protection unit in terminal box KL 1 or KL 2 with atmospheric pressure reference available on request

Electrical connection	
Cable with sheath material ⁴	PVC (-5 ... 70 °C) grey Ø 7.4 mm PUR (-25 ... 70 °C) black Ø 7.4 mm FEP ⁵ (-25 ... 70 °C) black Ø 7.4 mm TPE-U (-25 ... 125 °C) blue Ø 7.4 mm TPE-U ⁶ (-25 ... 125 °C) red Ø 9.0 mm
Bending radius	static installation: 10-fold cable diameter dynamic application: 20-fold cable diameter

⁴ shielded cable with integrated ventilation tube for atmospheric pressure reference

⁵ do not use freely suspended probes with an FEP cable if effects due to highly charging processes are expected

⁶ only in combination with IS version (explosion protection) and temperature element Pt 100

Materials (media wetted)	
Housing	stainless steel 1.4404 (316 L)
Seals	FKM, FFKM, EPDM others on request
Diaphragm	standard: ceramics Al ₂ O ₃ 96 % option: ceramics Al ₂ O ₃ 99.9 %
Protection cap	POM-C
Cable sheath	PVC, PUR, FEP, TPE-U

Explosion protection (only for 4 ... 20 mA / 2-wire)	
Approval DX14-LMK 382	IBExU05ATEX1070 X zone 0 ⁷ : II 1G Ex ia IIB T4 Ga zone 20: II 1D Ex ia IIIC T110 °C Da
Safety technical maximum values (pressure)	$U_i = 28 \text{ V}$, $I_i = 93 \text{ mA}$, $P_i = 660 \text{ mW}$, $C_i = 14 \text{ nF}$, $L_i \approx 0 \text{ }\mu\text{H}$, $C_{\text{grd}} = 27 \text{ nF}$
Safety technical maximum values (temperature)	$U_i = 30 \text{ V}$, $I_i = 54 \text{ mA}$, $P_i = 405 \text{ mW}$, $C_i = 0 \text{ nF}$, $L_i = 0 \text{ }\mu\text{H}$ (temperature element Pt 100)
Permissible media temperature	in zone 0: -10 ... 60 °C with p_{atm} 0.8 bar up to 1.1 bar zone 1 and higher: -10 ... 70 °C
Connecting cables (by factory)	cable capacitance: signal line/shield also signal line/signal line: 220 pF/m cable inductance: signal line/shield also signal line/signal line: 1.5 $\mu\text{H}/\text{m}$
⁷ for optional stainless steel pipe following designation is valid: "II 1G Ex ia IIC T4 Ga" (zone 0)	
Miscellaneous	
Option cable protection for probes	prepared for mounting with stainless steel pipe
Current consumption	max. 21 mA
Weight	approx. 400 g (without cable)
Ingress protection	IP 68
CE-conformity	EMC Directive: 2014/30/EU
ATEX Directive	2014/34/EU
Wiring diagrams	
<p>2-wire-system (current)</p>	<p>3-wire-system (voltage)</p>
<p>2-wire-system current (pressure) / 3-wire-system (temperature Pt 100)</p>	
Pin configuration	
Electrical connection	cable colours (IEC 60757)
for Pt 100:	<ul style="list-style-type: none"> Supply V_s+ WH (white) Supply V_s- BN (brown) Supply T+ YE (yellow) Supply T- GY (grey) Supply T- PK (pink)
for 3-wire:	<ul style="list-style-type: none"> Signal + GN (green) Shield GNYE (green-yellow)

Dimensions (mm / in)

standard

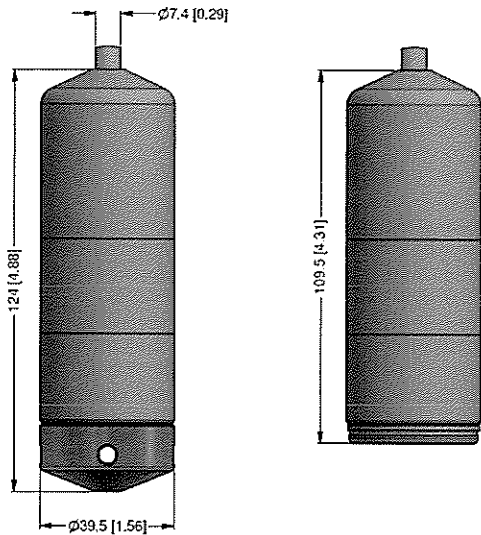

protection cap removable

option

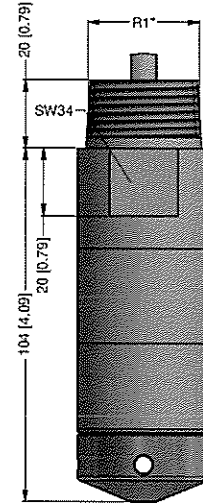

prepared for mounting with stainless steel pipe

flange version

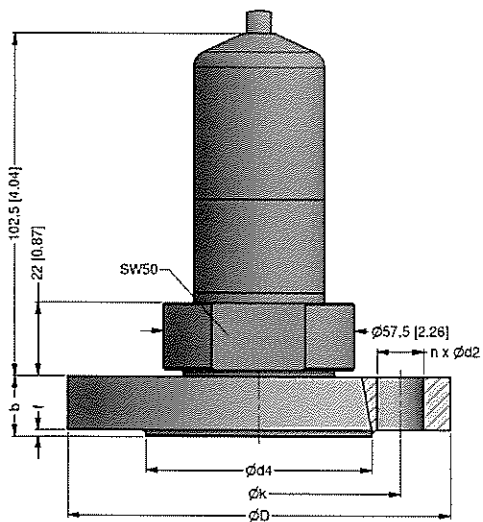

⇒ transmitter flange is not part of supply and has to be ordered separately

⇒ cable diameter 8 mm for TPE-U cable (red), drawings for option with Pt 100 on request

Transmitter flange for flange version																																							
		<table border="1"> <thead> <tr> <th colspan="4">dimensions in mm</th> </tr> <tr> <th>size</th> <th>DN25 / PN40</th> <th>DN50 / PN40</th> <th>DN80 / PN16</th> </tr> </thead> <tbody> <tr> <td>b</td> <td>18</td> <td>20</td> <td>20</td> </tr> <tr> <td>D</td> <td>115</td> <td>165</td> <td>200</td> </tr> <tr> <td>d2</td> <td>14</td> <td>18</td> <td>18</td> </tr> <tr> <td>d4</td> <td>68</td> <td>102</td> <td>138</td> </tr> <tr> <td>f</td> <td>2</td> <td>3</td> <td>3</td> </tr> <tr> <td>k</td> <td>85</td> <td>125</td> <td>160</td> </tr> <tr> <td>n</td> <td>4</td> <td>4</td> <td>8</td> </tr> </tbody> </table>		dimensions in mm				size	DN25 / PN40	DN50 / PN40	DN80 / PN16	b	18	20	20	D	115	165	200	d2	14	18	18	d4	68	102	138	f	2	3	3	k	85	125	160	n	4	4	8
dimensions in mm																																							
size	DN25 / PN40	DN50 / PN40	DN80 / PN16																																				
b	18	20	20																																				
D	115	165	200																																				
d2	14	18	18																																				
d4	68	102	138																																				
f	2	3	3																																				
k	85	125	160																																				
n	4	4	8																																				
Technical data																																							
Suitable for	LMK 382, LMK 382H, LMK 458, LMK 458H																																						
Flange material	stainless steel 1.4404 (316L)																																						
Hole pattern	according to DIN 2507																																						
Ordering type	Ordering code	Weight																																					
Transmitter flange DN25 / PN40	ZSF2540	1.2 kg																																					
Transmitter flange DN50 / PN40	ZSF5040	2.6 kg																																					
Transmitter flange DN80 / PN16	ZSF8016	4.1 kg																																					

Mounting flange with cable gland																																							
		<table border="1"> <thead> <tr> <th colspan="4">dimensions in mm</th> </tr> <tr> <th>size</th> <th>DN25 / PN40</th> <th>DN50 / PN40</th> <th>DN80 / PN16</th> </tr> </thead> <tbody> <tr> <td>b</td> <td>18</td> <td>20</td> <td>20</td> </tr> <tr> <td>D</td> <td>115</td> <td>165</td> <td>200</td> </tr> <tr> <td>d2</td> <td>14</td> <td>18</td> <td>18</td> </tr> <tr> <td>d4</td> <td>68</td> <td>102</td> <td>138</td> </tr> <tr> <td>f</td> <td>2</td> <td>3</td> <td>3</td> </tr> <tr> <td>k</td> <td>85</td> <td>125</td> <td>160</td> </tr> <tr> <td>n</td> <td>4</td> <td>4</td> <td>8</td> </tr> </tbody> </table>		dimensions in mm				size	DN25 / PN40	DN50 / PN40	DN80 / PN16	b	18	20	20	D	115	165	200	d2	14	18	18	d4	68	102	138	f	2	3	3	k	85	125	160	n	4	4	8
dimensions in mm																																							
size	DN25 / PN40	DN50 / PN40	DN80 / PN16																																				
b	18	20	20																																				
D	115	165	200																																				
d2	14	18	18																																				
d4	68	102	138																																				
f	2	3	3																																				
k	85	125	160																																				
n	4	4	8																																				
Technical data																																							
Suitable for	all probes																																						
Flange material	stainless steel 1.4404 (316L)																																						
Material of cable gland	standard: brass, nickel plated		on request: stainless steel 1.4305 (303); plastic																																				
Seal insert	material: TPE (ingress protection IP 68)																																						
Hole pattern	according to DIN 2507																																						
Ordering type	Ordering code	Weight																																					
DN25 / PN40 with cable gland brass, nickel plated	ZMF2540	1.4 kg																																					
DN50 / PN40 with cable gland brass, nickel plated	ZMF5040	3.2 kg																																					
DN80 / PN16 with cable gland brass, nickel plated	ZMF8016	4.8 kg																																					

Terminal clamp			
Technical data			
Suitable for	all probes with cable Ø 5.5 ... 10.5 mm		
Material of housing	standard: steel, zinc plated		optionally: stainless steel 1.4301 (304)
Material of clamping jaws and positioning clips	PA (fibre-glass reinforced)		
Dimensions (mm)	174 x 45 x 32		
Hook diameter	20 mm		
Ordering type	Ordering code	Weight	
Terminal clamp, steel, zinc plated	Z100528	approx. 160 g	
Terminal clamp, stainless steel 1.4301 (304)	Z100527		

© 2022 BDSSENSORS GmbH - The specifications given in this document represent the state of engineering at the time of publishing. We reserve the right to make modifications to the specifications and materials.

