

Technical data sheet

Surge protection module 150 V

Item no. 5092466

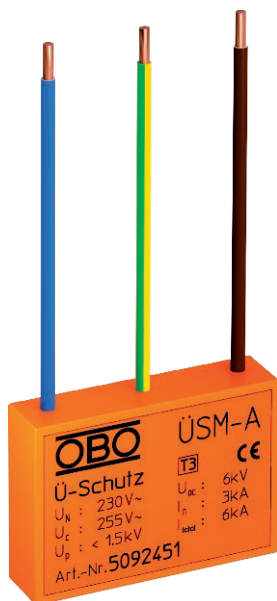

Surge protection module type 3 to DIN EN 61643-11 for 150 V power grids.

- With acoustic defect signal
- With low construction height
- Y circuit

Application: Universal applicable for all installation systems



Dimensions

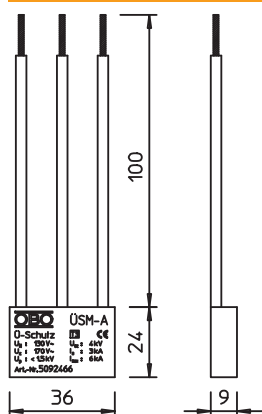

Master data

Item no.	5092466
Type	ÜSM-A-150
Description 1	Surge protective Modul
Description 2	for all installation systems
Dimension	150V
Smallest sales unit (VG)	1,00 Piece
Weight	1,50 kg/100 pc.

Technical data sheet

Surge protection module 150 V

Item no. 5092466



Technical data

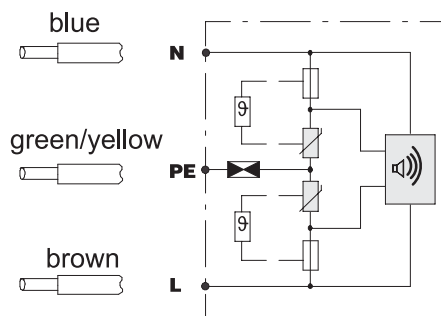

SPD to EN 61643-11	Type 3
SPD to IEC 61643-11	Class III
Nominal voltage	150,00 V
Maximum continuous voltage AC	170,00 V
Max. continuous operating voltage	170,00 V
Nominal discharge current (8/20)	3 kA
Rated current	16,00 A
Maximum discharge current (8/20 μ s)	6,00 kA
Protection level	< 1,3 kV
Protection level (L-N)	< 1,3 kV
Protection level (N-PE)	< 1,5 kV
Response time	< 25 ns
Maximum back-up fuse	16,00 A
Temperature range	-15+60 °C
Pole version	Other
Version	Acoustic operating display
Version	Other
Signalling on device	Acoustic